

15112 NATIONAL PIKE
HAGERSTOWN MD 21740



PHONE 301-582-0640
FAX (301) 582-3618

HAGERSTOWN SPEEDWAY

2013 LATE MODEL DIVISION

SPECIFICATIONS

WHEEL BASE - Minimum wheel base allowed is 103 inches.

BODIES - All cars must have a complete stock appearing body including windshield post. Roof line must remain in a level or stock position and fasten to the outside edge of body on both sides, and the window openings close to stock. Quarter panels should remain in a manner that does not take away from the appearance of the car. A full head with presentable lines is required, carburetor clearance allowed, as long as it is neat in appearance. Floor boards and firewall must cover driver's area and must be constructed to provide maximum safety that a minimum 1/8 inch steel or 1/4 inch aluminum be used as floor boards in the driver's foot and leg area. Driver's seat must remain in the same general area as original, and the area to the right of the driver must be designed in such a manner that a driver has ample room to escape in the event of an accident. It is mandatory that the sheet metal from the driver's area to the right side door window be installed at an upward angle. All windows must remain open; windshield screens or bars mandatory. No wings or body skirting allowed. No fender skirts allowed. Spoiler should be made of clear, see-through material. Neatly painted numbers at least 18 inches high on both sides (at the door area) and roof of car is mandatory. Any one(1) or two(2) piece front nose spoiler allowed. Tow hooks are **MANDATORY** on all cars.

**PLEASE SEE LATE MODEL BODY SPECIFICATIONS FOR BODY DIMENSIONS.
THESE SPECIFICATIONS WILL BE STRICTLY ENFORCED.**

FRAMES - Any manufactured full frame or a stock appearing front frame section attached to a steel rail frame with a minimum of eight(8) inch circumference, reaching from the front subframe through to the rear bumper supports.

ROLL CAGES - Cars must have a suitable roll cage in the driver's compartment, including a head rest; all suitable reinforced with gusset plates at welds and all well padded with substantial padding material. Side roll bars are compulsory and must extend into the door panels. A minimum of 3 bars on the left side and 3 bars on the right side must be used. A minimum of one and a half inch diameter, with a wall thickness of .095 or equivalent is required. Roll cage must be attached to frame section.

BUMPERS AND RUB RAILS - Cars must be equipped with securely fastened front and rear bumpers. Additional bracing of bumpers is permitted, but should not extend more than six inches above stock bumpers. If rub rails are utilized, they must be attached flush with body contours.

ENGINES - Engines used must be factory produced and naturally aspirated. Engines must be in the manufacturers line - i.e. General Motors product in a General Motors line, Ford Motors in a Ford Motors line, etc. Engine setback is measured from the mid-plate to the center of the upper A-frame bolts and equals 25 ½ inches. No tolerance. All cars will be limited to one (1) carburetor not be exceed four(4) barrels. Magnetos and electric fuel pumps are allowed. Aluminum blocks allowed. Fuel injection is not allowed.

HEADERS - Headers must be (4) pipes to (1) pipe to be straight with car and no turning toward track, can be turned out from under car. No 180 degree, or zoomie headers allowed.

MECHANICAL CONDITION - Cars must be in good mechanical condition, presentable in appearance and equipped with operating self-starters and four wheel hydraulic disc brakes.

TRANSMISSION AND CLUTCH - Any type transmission with a working reverse, and working forward gears. Cars must be equipped with an operational clutch. Automatic transmission allowed. Transmission must be mounted to rear of engine and only one drive shaft permitted. Any type of fly wheel may be used. Fly wheel must have a starter ring in working order. Fly wheel and pressure plate, or approved typed and securely attached to engine and transmission assembly. Special construction all-steel clutch housings are permitted. Triple disc clutches permitted with aluminum casing.

SUSPENSION SYSTEMS - Front suspensions must be of stock configuration. No center steering. Rack and pinion steering is permitted. Steering must be mounted to the front frame. Any type shock absorber may be used. No torsion bar systems allowed. No driver controlled weight jacks allowed. No driver controlled suspension adjusting system allowed.

REAR ENDS - Quick change rear ends allowed. No multiple speed rear ends. No open tube rear ends.

SAFETY EQUIPMENT - No batteries located in the driver's compartment. A drive line sling is required. All cars should have an approved fire extinguisher securely mounted in

reach of driver A 5 pound halon system recommended. Drivers are required to wear fire resistant uniforms. Fire resistant shoes, gloves, and head piece recommended. Window nets recommended but are not mandatory as long as a self contained seat is being used. Arm restraints highly recommended. Bucket type seats, and racing type seat belts and shoulder harness must be securely fastened to frame. No rear view mirrors.

FUEL SYSTEMS - The fuel tank must be securely mounted in a 20-gauge steel box with two(2) 1/8 inch by 1 inch straps, with a fire wall between tank and driver's compartment. An approved fuel cell must be used, one per car. Any fuel may be used. No nitrous type additives are allowed. Tank must be located in trunk area. PLEASE SEE Late Model Body Specifications

RADIATORS - The main radiator must be located in front of the engine. An auxiliary radiator small in volume may be added, providing, that if an auxiliary water or oil cooler is used, it must be enclosed so as to protect the driver in case of failure and must be located so as not to be visible from outside the car or to change the body appearance.

TIRES - Largest tire permitted is the Hoosier Economy 11 inch tire measuring 16 3/4 inches sidewall to sidewall with a 93 inch circumference. These are maximum measurements with no tolerance. Hoosier is the only brand tires permitted no compound specifications.

WHEELS - Any approved racing wheels are allowed. No knock off type wheels allowed. Wheels are limited to a maximum rim width of fourteen (14) inches.

WEIGHT LIMIT - A minimum weight limit is in effect. This weight limit is with driver at the finish of the race without adding fuel. The minimum weight limit is: Ford and GM products: 2250 lbs. All other Products: 2150lbs. Weight limit will be by engine make and not body type. Scales will be available for weighing any time during a race. Officials have the right to weigh a car at their convenience. The speedway's certified scales will be the official weigh device for all sanctioned races and competitors must abide by track scales. Added ballast or weight will be allowed, but must be securely fastened. If a car fails to make a legal weight after a race, it will be disqualified and additional penalties as officials deem necessary.

RADIOS--No devices such as radios for communication are permitted.

PENALTIES - At any time the conduct of any team member or driver is a discredit to the speedway, the racing industry, or to himself, he may be removed from all racing activity at the speedway. The driver is responsible for all the people associated with his car or signed in with the car. If you can't be ladies and gentlemen, we don't recommend you participate at Hagerstown Speedway. (Officials have the right to make you place more weight on car if you don't abide by these rules as stated in this rule book.)

THE OFFICIAL'S INTERPRETATION OF THESE RULES SHALL BE ACCEPTED AS BINDING.

NOTE: ANYTHING NOT COVERED IN THESE RULES WILL BE UP TO THE DISCRETION OF THE SAFETY OFFICIALS WITHOUT RECOURSE FROM DRIVERS OR OWNERS. ALL OF THE PRECEDING RULES ARE SUBJECT TO REVISION. THE OFFICIAL IN CHARGE RESERVES THE RIGHT TO MAKE DECISIONS AND JUDGE ACCORDINGLY. TRACK OFFICIALS HAVE THE RIGHT TO REFUSE ANY CAR OR DRIVER THAT DOES NOT MEET SPECIFICATIONS

LATE MODEL BODY SPECIFICATIONS

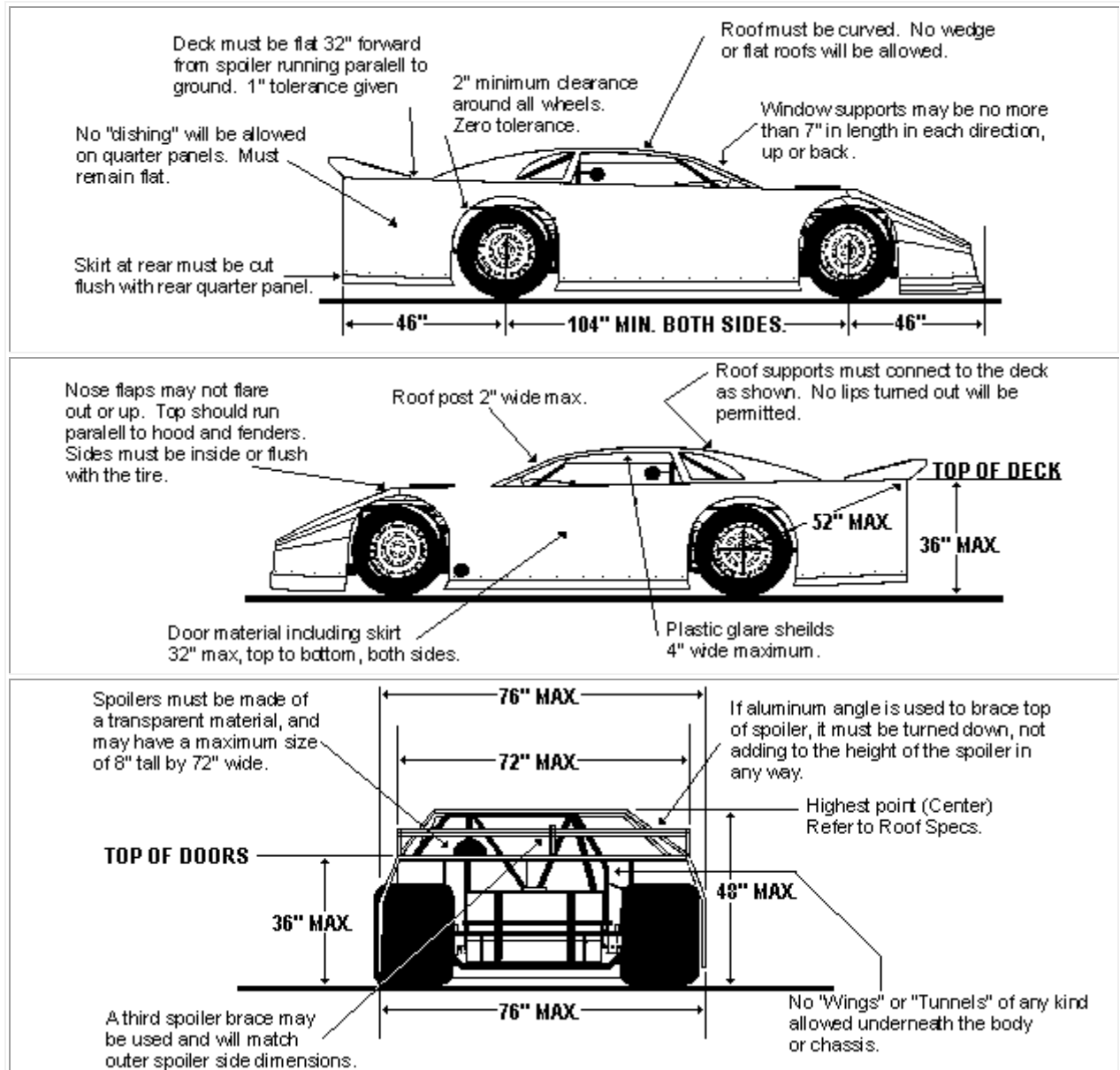

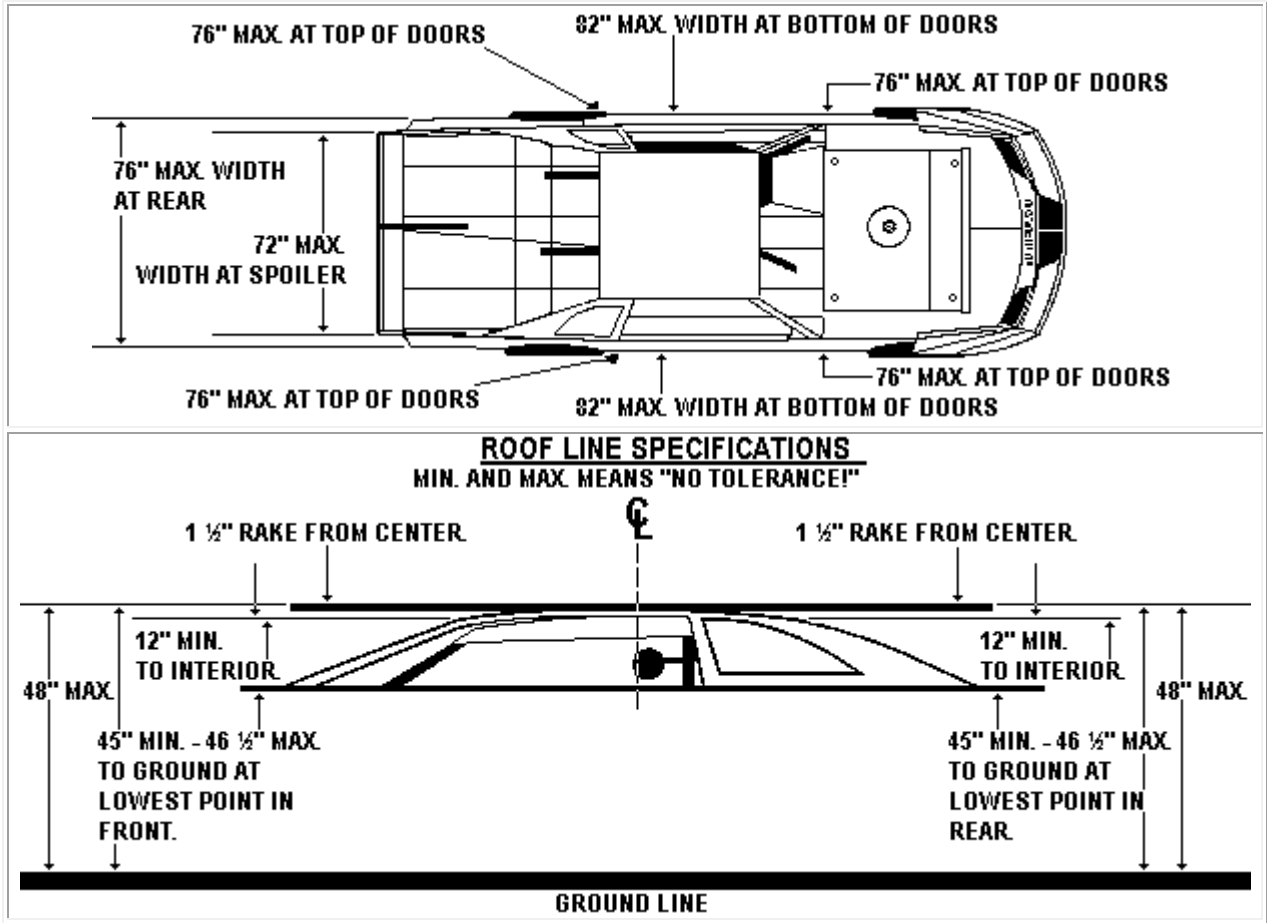

LATE MODEL FUEL CELL & VALVE SPECS

